

STEREO LOW VOLTAGE CASSETTE PREAMPLIFIER

- LOW ON/OFF POP NOISE
- LOW OPERATING VOLTAGE
- VERY LOW DISTORTION

The TDA7282 is a monolithic integrated circuit intended for stereo cassette players.

The TDA7282 is assembled in 8 leads plastic minidip.

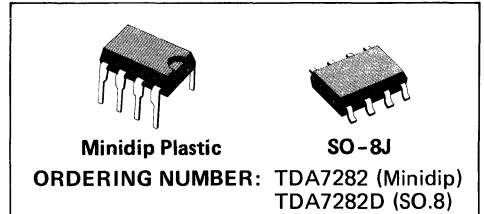

ABSOLUTE MAXIMUM RATINGS

V_s	Supply voltage	10	V
T_{stg}, T_j	Storage and junction temperature	-40 to +150	°C
P_{tot}	Total power dissipation at $T_{amb} = 70^\circ\text{C}$	400	mW

STEREO PREAMPLIFIER FOR CASSETTE PLAYERS

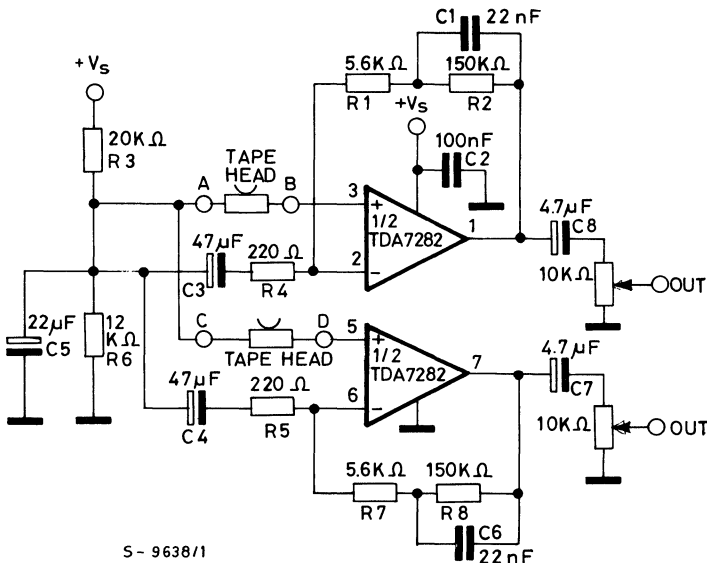

CONNECTION AND BLOCK DIAGRAM

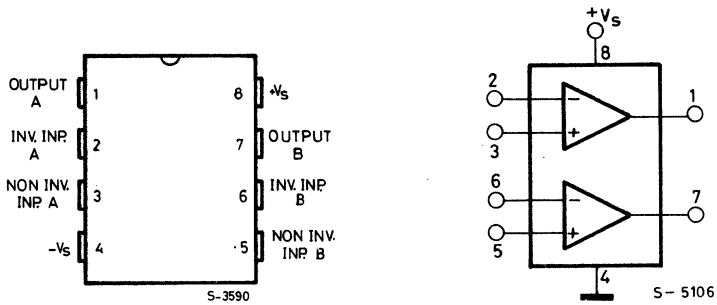

TEST CIRCUIT

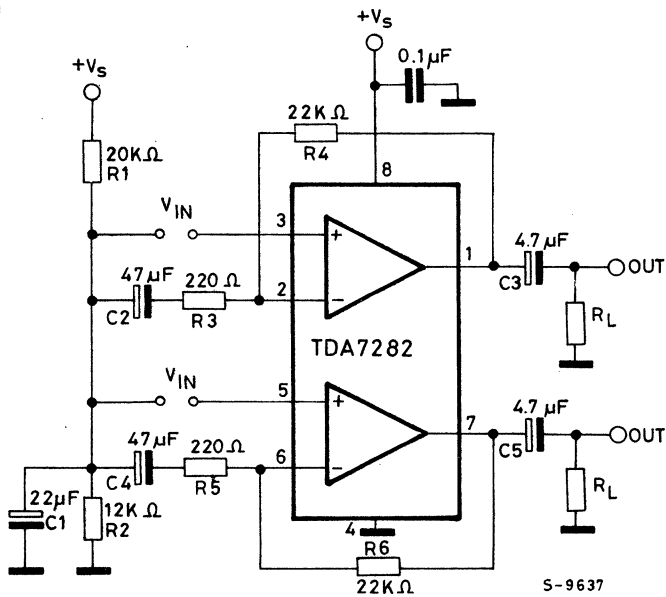

THERMAL DATA

$R_{th\ j-amb}$	Thermal resistance junction-ambient	max	200	°C/W
-----------------	-------------------------------------	-----	-----	------

ELECTRICAL CHARACTERISTICS ($V_s = 3V$, $T_{amb} = 25^\circ C$, $f = 1KHz$, $G_v = 40dB$, $R_L = 10K\Omega$, $R_s = 600\Omega$ unless otherwise specified)

Parameter	Test Conditions	Min.	Typ.	Max.	Unit
V_s	Supply voltage	1.8		9	V
I_d	Supply current		1.5	3	mA
I_b	Input bias current		280	500	nA
I_{os}	Input offset current		20		nA
V_{os}	Input offset voltage		0.5		mV
V_{oDC}	Quiescent voltage		1.1		V
V_o	Output voltage	THD = 1%	550	650	mV
THD	Total harmonic distortion f = 100Hz f = 1KHz f = 10KHz	$V_o = 300mV$		0.08 0.07 0.1	% % %
G_v	Open loop voltage gain	f = 1KHz	68	80	dB
G_v	Closed loop gain		40		dB
	Channel balance		0.5		dB
e_N	Total input noise voltage	$B_W = 22KHz$ to $22KHz$		1.5	μV
C_S	Channel separation	f = 1KHz $V_o = 30mV$		65	dB
SVR	Supply voltage rejection	f = 100Hz	36	45	dB
R_{IN}	Input resistance		100		$K\Omega$
R_o	Output resistance		15		Ω

APPLICATION INFORMATION

Fig. 1 - Stereo preamplifier for cassette players

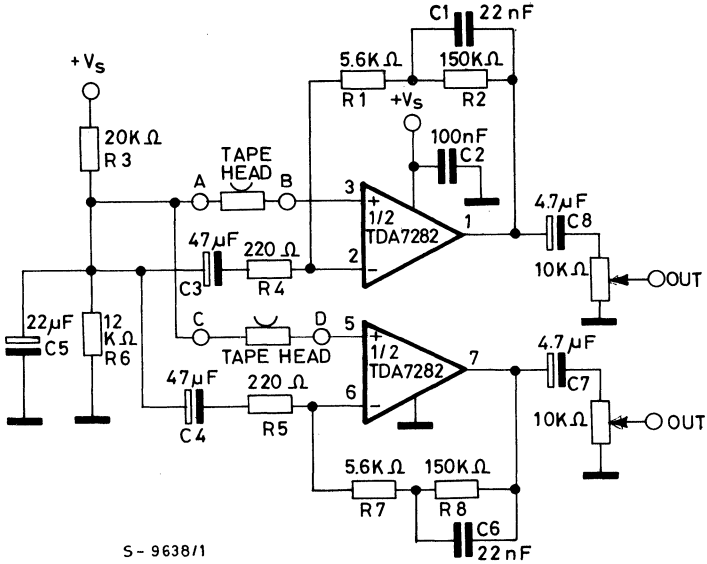
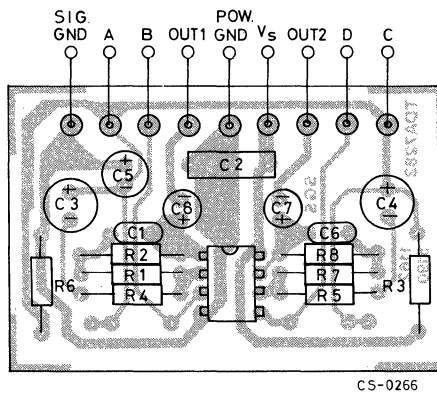

Fig. 2 - P.C and components layout of the circuit of Fig. 1 (1 : 1 scale)



APPLICATION INFORMATION (continued)

Fig. 3 - Quiescent current vs. supply voltage

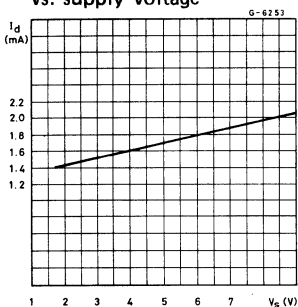

Fig. 4 - DC output voltage vs. supply voltage

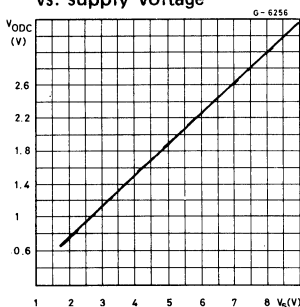

Fig. 5 - Input bias current vs. supply voltage

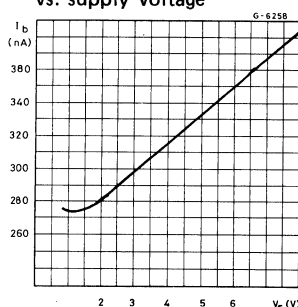

Fig. 6 - Distortion versus output level

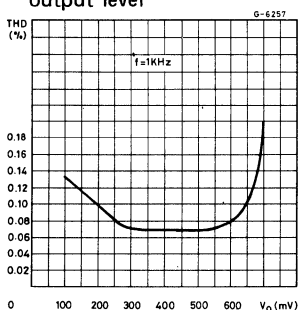

Fig. 7 - Distortion vs. frequency

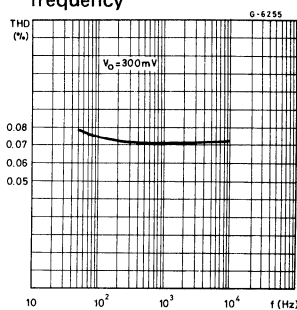

Fig. 8 - NAB response of the circuit of Fig. 1

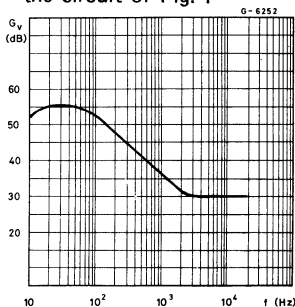

Fig. 9 - Supply voltage rejection vs. frequency

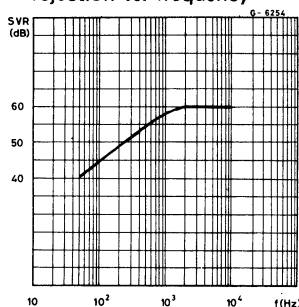
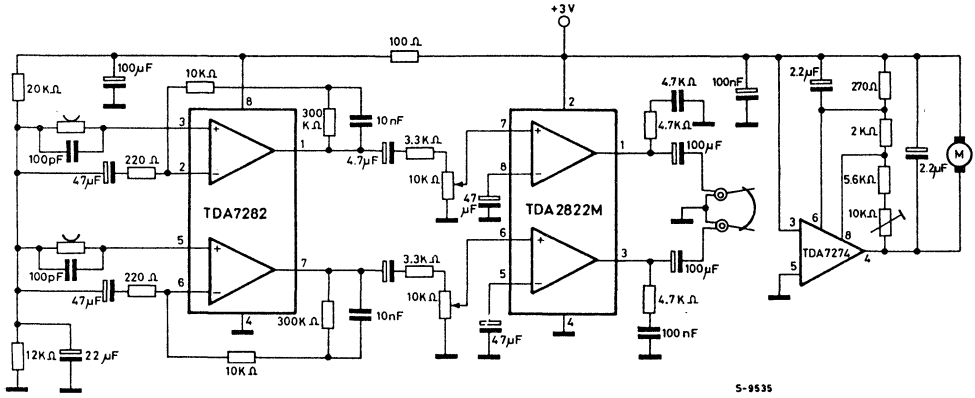

Fig. 10 - Stereo cassette player with motor speed control



5-9535